

BD - 05T Series - Micro Piezoelectric pump

Model:BD-05T01PZ20

The device operates as an air pump (fan) by using a piezoelectric element to generate ultrasonic vibrations, enabling a compact structure, low-noise performance, and an optimized balance between pressure and airflow.



Performance Data	
Model	BD-05T01PZ20
Input Voltage	60 - 70 VPP
Ambient Temperature Range	5-50 ° C
Drive Frequency	18-22 kHz
Flow Rate @ 28 VDC	≥ 0.8 L/min
No-Load Flow Rate	0.8 L/min
Static Pressure	≥ 20 kPa
Static Pressure	≤-15kpa

- Note**
1. A dedicated driver circuit is required. The driver circuit should be supplied with 3.7-5 VDC
 2. Test conditions: Ambient temperature: 20 - 28 ° C; Atmospheric pressure: 950 - 1020 hPa.
 3. Flow rate and pressure may vary with changes in temperature and atmospheric pressure.
 4. Excessive voltage will significantly reduce the pump ' s reliability and service life, especially when continuous operation at high voltage causes heat buildup.
 5. During continuous operation, temperatures above 60 ° C may cause functional damage. It is recommended to use the pump in an environment below 60 ° C.
 6. The airflow direction is unidirectional and follows the arrow marking only. Reverse airflow is not allowed.
 7. This miniature air pump is not waterproof and must not be exposed to liquids or cleaned with water. Clean only with a slightly damp cloth. Avoid operation in high-humidity environments where condensation may occur.
 8. Do not operate the pump in dusty environments. Airborne particles may accumulate inside the pump chamber. Operation in filtered submicron-particle environments or cleanroom conditions is recommended. Please note that filters alone cannot completely prevent degradation of pump performance or service life.
 9. In particular, avoid operation in environments exposed to smoke, such as cigarette smoke, mosquito coil smoke, or similar airborne contaminants.
 10. Do not manually disassemble or bend the pump body, including the nozzle, wiring, fittings, or connectors.

Drawing(mm) Nozzle diameter:4mm

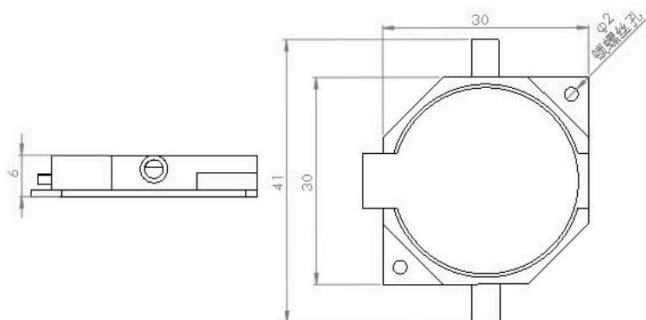

Curve

